

ROGER ACCESS CONTROL SYSTEM

PRT32 v1.0 RFID/PIN Access Reader

Firmware v74.7

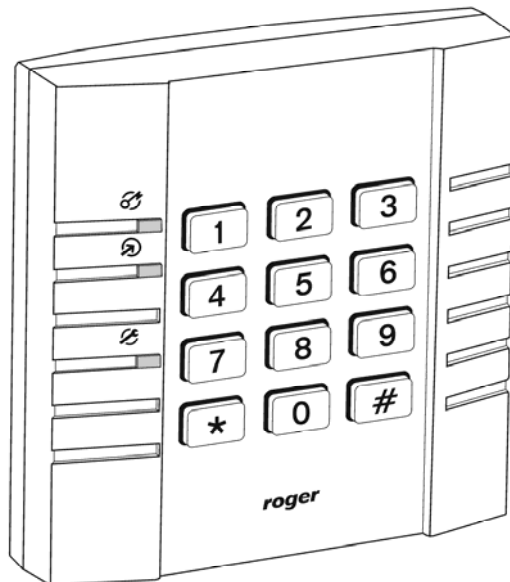

Installation and Programming Guide



1. Table of contents

1. Table of contents	2
2. Important note – read this first	3
3. Glossary and terms	3
4. General	4
4.1. Designed function	4
4.2. Features	5
5. Operating modes	5
5.1. Online mode (host-controlled operation)	5
5.1.1. <i>Wiegand format</i>	6
5.1.2. <i>Magstripe format</i>	6
5.1.3. <i>RACS format</i>	7
5.2. Offline Mode (Stand-alone Operation)	7
5.2.1. <i>Full Stand-alone mode</i>	7
5.2.2. <i>Simple Stand-alone mode</i>	8
6. Functional description for Offline mode	8
6.1. Users	8
6.2. Managing the users	9
6.3. User identification	9
6.4. Armed and Disarmed Modes	10
6.5. Arming and disarming of a reader	10
6.5.1. <i>Examples</i>	11
6.6. Unlocking a door	11
6.7. Operation with XM-2 I/O extension module	12
6.8. Operation with the external PRT series reader	12
6.9. Door Bell function	13
6.10. Alarms	13
7. Programming	14
7.1. Preparing the reader for Online mode	14
7.2. Preparing the reader for Offline mode	14
7.3. Setting the reader's operation mode	14
7.4. Memory Reset - programming MASTER and INSTALLER users	16
7.4.1. <i>Factory default settings</i>	16
7.5. Installer Programming mode	17
7.6. User Programming mode	19
7.6.1. <i>User programming commands</i>	20
7.6.2. <i>Programming examples</i>	21
8. Acoustic and optical signals in Offline mode	22
9. Installation guidelines	23
10. Appendix	24

2. Important note – read this first

The PRT32 can be configured for various operating modes. The factory shipped new reader is pre-configured for **RACS address ID=0**. The selection of the required operating mode can be carried out through adequate programming procedure (see **Setting reader operating mode** later in this document).

If the reader is dedicated for *Offline* mode (standalone mode) installer must program two special users (MASTER and INSTALLER) into a unit, those users will be later required for programming of a unit.

If the unit is dedicated for *Online* mode (slave unit connected to the host controller) programming of the MASTER and INSTALLER users is not necessary.

Both users (MASTER and INSTALLER) may have card and/or PIN. Any EM 125 kHz proximity card or tag can be programmed for MASTER or INSTALLER. Whenever required (e.g. when stolen or lost) installer may program new MASTER and INSTALLER cards into a unit. The factory new PRT32 reader is shipped with MASTER and INSTALLER users not programmed.

Note: If after power up of the reader the LED SYSTEM  is on it means that either contents of reader's memory is corrupted or MASTER/INSTALLER users are not programmed into a unit. In this case reader must be completely re-programmed.

3. Glossary and terms

Clock & Data Interface

The electrical interface used by the reader for communication with various equipment connected to it. Optionally, the PRT32 can operate with a second PRT series reader and XM-2 I/O extension module. These devices can be connected to the same *Clock* and *Data* lines and must have an individual addresses (ID numbers).

Door Release or Door Lock

The electric device used to unlock a door. Typically it can be a door strike or magnetic lock.

Identifier

The method or means which is used for identification of a user. It can be a proximity card, a PIN code, a finger template etc. In some cases *Identifier* may consist of two or more of items required for a single identification procedure. For example when the option *Card and PIN* is active then *Identifier=Card+PIN*.

Identification Mode

The method used for identification of users. The PRT32 offers following *Identification Modes: Card or PIN* and *Card and PIN*.

Memory Reset

The procedure which clears contents of device's memory and restores default (factory) values.

PRT Series Readers

The PRT reader's family developed and manufactured by the Roger. Each member

of PRT series readers can be connected to the external access controller (this is called *Online* mode) or operate as stand-alone unit (this is called *Offline* mode).

Restart

The scenario when device goes through initialization procedure, the same as after power up of a unit.

Roger Access Control System (RACS)

The access control system which consists of PR series access controllers developed and manufactured by Roger.

Access Control Unit (ACU)

The logic device which provides access control, usually it is an access controller.

XM-2 I/O Extension Module

The remote I/O extension module for RACS system. The XM-2 provides two NO/NC inputs and two relay type outputs.

Full Stand-alone mode

The operation mode in which reader independently controls a door passage. When in *Full Stand-alone mode* PRT32 requires the remote XM-2 extension module, optionally it may operate with additional PRT series reader (two-way passage).

Simple Stand-alone mode

The operation mode in which reader independently controls a door passage. When in *Simple Stand-alone mode* PR32 uses its internal I/O lines as general purpose I/Os and is not capable to operate with XM-2 I/O module nor additional PRT reader.

4. General

4.1. Designed function

The PRT32 reader has been designed for use in access control installations to enable user identification via EM 125 kHz UNIQUE standard proximity cards and/or PIN codes. Reader can be configured for *Stand-alone* mode (alternatively called *Offline* mode) or for use with an external access control unit (ACU) supporting compatible data interface formats (*Online* mode).

The PRT32 configured for *Online* mode works as a slave unit serving a sole purpose of reading cards and/or entering a PIN codes then providing subsequent transmission of such collected data to the host ACU for further processing.

The PRT32 terminal offers several data transmission formats available for use in *Online* mode which includes the popular *Wiegand* and *Magstripe* (i.e. simulation of an output of a magnetic card reader) data protocols.

When configured for *Stand-alone* operation (*Offline* mode), the PRT32 reader independently (i.e. autonomously) controls the supervised door access point. For this mode the reader offers two installation configurations — first of them uses the reader's built-in I/O signal lines as standard general purpose inputs and outputs, the second one uses them for communication with an external XM-2 I/O module and a secondary (optional) PRT series reader. An access control installation containing two PRT series readers (one at the entry and other at the exit side of the

supervised door) enables two-way passage control. The system setup utilizing an XM-2 module provides higher level of security for door access control system by separating its logical element (a reader unit) from the relay which controls a door lock.

Note: When configured for *Full Stand-alone* mode, the PRT32 reader may operate with the second PRT series reader. Both devices can create two way (entry/exit) door control.

4.2. Features

Online mode (Slave unit connected to a host device):

- 26/34/42/66 bit Wiegand data transmission formats
- Magstripe data format (ABA Track II emulation)
- RACS data format (for connection to PR series ACUs from Roger)
- Various options for transmission of PIN codes
- LED/BUZZER control input

Offline mode (Stand-alone mode):

- System settings stored in nonvolatile memory
- Enrolment up to 120 users
- User identification by a card or PIN code
- User indexing (ID indexed user records)
- Support for **Door Contact** and **Exit Button**
- **Door Alarm** and **Door Bell** outputs
- **Disarmed Mode** output and **Arming Disabled** input for integration with the alarm system
- Two way door control (requires second PRT reader to form a pair)
- Uses built-in I/Os or remote XM-2 I/O module

5. Operating modes

There are two main modes of operation available for a reader:

- *Online* mode
- *Offline* mode

5.1. Online mode (host-controlled operation)

When in this mode, PRT32 reads cards or PINs and then transmits the collected data to the host unit for further processing. The PRT32 offers the following data transmission formats:

- Wiegand 26bit
- Wiegand 34bit
- Wiegand 42bit
- Wiegand 66bit
- Magstripe (ABA Track II emulation, sometimes called *Clock & Data*)
- RACS (for PR controllers from Roger)

5.1.1. Wiegand format

When employing *Wiegand* transmission format, the card/PIN is transferred to the host using sequences of pulses sent over the CLK and DTA lines. Depending on the selected version of the transmission format, the PRT32 uses 26, 34, 42 or 66 bits to transmit a data to the host unit. Card code is always transmitted as a whole number, PINs can be transmitted as a hole number too or alternatively, each pressed key can be transmitted separately (for more details regarding PIN transmission formats see section: Setting Reader Operating Mode).

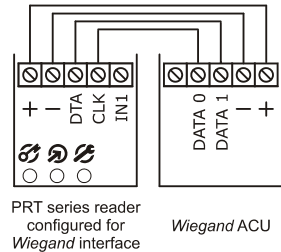

Note: For card and PIN codes which require more bits than the number of bits available in the selected data transmission format, the PRT32 reader omits the most significant bits of the code/PIN. As a result transmission from a reader is not equal to a full code of presented card code or entered PIN.

In *Wiegand* format, a dual color LED STATUS lights steady in red. The LED SYSTEM along with buzzer are activated for a while each time a card is read or PIN is entered. The LED OPEN is normally off, it becomes on when IN1 is shorted with supply negative (GND), also when active, the LED OPEN is accompanied by continues sound.

5.1.2. Magstripe format

When employing *Magstripe* transmission format, the card/PIN is transferred to the host using electric signal waves transmitted over the CLK and DTA lines. The LED indicators and the buzzer are controlled in the same manner as described for *Wiegand* formats (see section above).

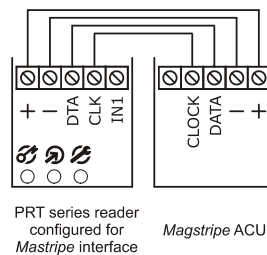

In *Magstripe* format, the PRT32 reader transmits a sequence of data bits representing either a code of the presented card or digits of entered PIN. When operating with *Magstripe* format, the reader stores all pressed keys in a buffer and does not transmit them until the [#] key is pressed — a press of the [#] key is treated as the end of the PIN code.

5.1.3. RACS format

When employing RACS transmission format, the PRT32 unit communicates with PR access controller via CLK and DTA lines. Unlike in the *Wiegand* and *Magstripe* formats, the PRT32 unit using RACS format requires an individual address (ID=0...3) to be set during configuration of a reader. With RACS format, communications between the PRT32 and ACU is bilateral, this allows controller to monitor communication. The reader's LEDs and the buzzer are controlled by the host except situation when reader will lost communication with host. In this case are LEDs are flashing which means that communication between reader and host is discontinued.

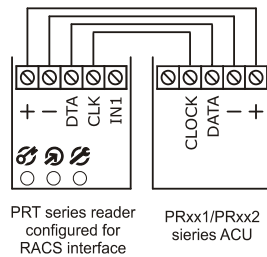

When operating with RACS format, reader stores all pressed keys in a buffer and does not transmit them, until the [#] key is pressed. Each entry of PIN code must be followed by pressing the [#] key, which is treated as the end of a PIN code. In RACS format when IN1 is triggered, the PRT32 will stop reading cards and PINs till the moment when IN1 will be released.

5.2. Offline Mode (Stand-alone Operation)

The PRT32 reader offers two variants of *Stand-alone* operation:

- *Full Stand-alone* mode
- *Simple Stand-alone* mode

In both operation modes reader is capable of providing independent (i.e. autonomic) control of a single door.

5.2.1. Full Stand-alone mode

In this mode the reader's CLK and DTA lines are used for communication with a remote XM-2 I/O extension module and optionally with second (optional) PRT series reader (for two-way door control). The IN1 line operates as a programmable input and can be configured to various options. The I/O lines on the XM-2 module can be programmed to several predefined functions (see: settings for C5, C6, C7, C8 and C9 parameters in section *Installer Programming*). The *Full Stand-alone* mode offers improved security, because it allows for separation between the reader and the relay which controls a door lock.

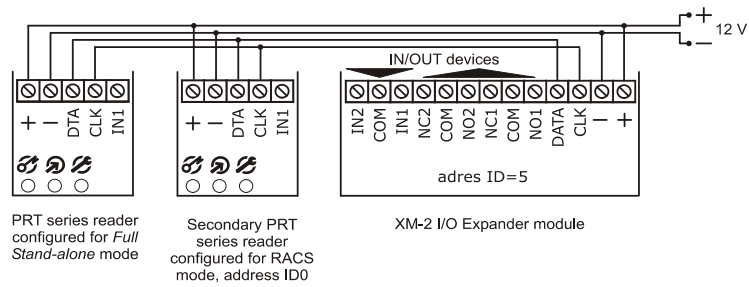

The maximum length of the cable run between a PRT reader and an XM-2 module and optional secondary PRT reader is limited to 150 m. For two-way door control the primary PRT unit needs to be configured for *Full Stand-alone* mode while the second (slave) reader needs to be configured for **RACS Online mode** with address set to **ID=0**.

Note: For *Full Stand-alone* mode the XM-2 I/O extension module connected to the PRT reader has to be configured for address ID=5.

5.2.2. Simple Stand-alone mode

In this mode the reader's CLK and DTA lines are used as standard, general purpose, inputs or outputs while the IN1 line operates always as a programmable input. Each I/O line (CLK, DTA and IN1) can be configured from several available functions.

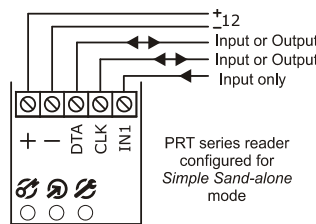

Note: The CLK and DTA lines may operate either as an input or output. Installer has to program each line for adequate function. The function assigned to CLK/DTA line automatically determines whether the line will operate as output or input. If configured to be an output, the CLK or DTA line operates as an open-collector line capable to sink up to 20 mA. When necessary, both lines (CLK and DTA) can be configured as **Door lock** output and connected together (shorted) for increased output current (up to 40mA).

6. Functional description for Offline mode

6.1. Users

In the *Offline (Stand-alone)* mode, a PRT reader can register up to 120 users, each with a card, PIN code (3-6 digits) and ID number (000–119). Every entry of a PIN code must be followed by the [#] key which is required to mark an end of a PIN. Users can be identified by their PINs or cards. When the *Card and PIN Identification Mode* is set, users must present their card and subsequently enter its PIN (always

first read card and then enter PIN). The *Card and PIN* option can be set separately for primary and secondary reader.

The PR32 reader supports five types (classes) of users:

- INSTALLER
- MASTER
- NORMAL
- TOGGLE
- TOGGLE LTD

User types (user classes)

INSTALLER	This user is authorized for entry to the <i>Installer Programming</i> mode only. Enter INSTALLER PIN or read INSTALLER Card and the reader will enter <i>Installer Programming</i> mode.
MASTER	This user is authorized for entry to the <i>User Programming</i> mode only. Enter MASTER PIN or read MASTER Card and the reader will enter <i>User Programming</i> mode.
NORMAL	NORMAL users are solely authorized to unlock the controlled door, they may have card and/or PIN.
TOGGLE	TOGGLE users are authorized to unlock the controlled door and to control the Armed/Disarmed mode of the reader, they may have card and/or PIN.
TOGGLE LTD	TOGGL LTD (TOGGLE LIMITED) are solely authorized to control the Armed/Disarmed mode of the reader, they may have card and/or PIN.

6.2. Managing the users

A new user can be registered in the device following either a simple or full programming procedure.

- *The simple programming procedure* consists of programming of a PIN code or card into the unit without specifying the ID number of a user to whom the programmed PIN/card will be assigned — so the system simply stores the code entered/card presented in first unoccupied ID number.
- *The full programming procedure* requires to specify the ID number for the new user being programmed which has to be followed by entering his PIN code and/or presenting his card.

Note: When you program a user using *full programming procedure*, you will be able later to selectively delete him by entering his ID number. If you program card/PIN using a *simple programming procedure* then to remove a given card/PIN from a reader you must present card to a reader or enter PIN code to be deleted, otherwise the only one method to remove it from the memory will be full *Memory Reset*.

6.3. User identification

In PRT32 user can be identified by card, PIN or both (card and PIN). The method

which reader uses for user's identification depends on the actual *Identification Mode*. The PRT32 enables following *Identification Modes*:

- *Card or PIN*, the reader requires card or PIN, only one of them is necessary for a successful identification
- *Card and PIN*, the reader requires card and PIN, both are necessary for a successful identification

Notes:

1. When *Card and PIN* mode is active, always first read a card and then enter a PIN.
 2. The *Identification Mode* can be set separately for primary and secondary reader.
-

6.4. Armed and Disarmed Modes

In *Stand-alone* mode reader may be *Armed* or *Disarmed*. The actual mode of the reader is indicated on the dual color LED STATUS , which lights in red for *Armed* and green for *Disarmed*. The actual mode in which reader is can be indicated on an output line configured to option **Disarmed Mode**. Such a configuration allows the output line to be used to control an arming mode of an alarm system to which reader is connected to or to switch on/off some other auxiliary system or device (e.g. heating, lights etc.). In general, the reader's *Armed/Disarmed* states have no effect on door unlocking, unless the **Access disabled when reader armed** option will be enabled. With this option activated, access to the supervised room may be granted only when reader operates in *Disarmed* mode.

Using the option mentioned above the TOGGLE and TOGGLE LTD users are capable to enable or disable access to the supervised room, also it allows automatic access locking upon a reader entering the *Armed* mode.

Note: Although the *Armed* and *Disarmed* modes of the reader were originally designed for integration with the alarm system, they can be successfully used for any other purpose which requires an on/off control method (light control, heating control etc).

Note: Upon powering on, the PRT32 automatically returns to the arming mode (*Armed* or *Disarmed*) it was in before powered off. Also, the reader returns to its original *Armed/Disarmed* state after leaving the programming mode. After *Memory Reset* controller always enters the *Armed* mode.

6.5. Arming and disarming of a reader

The action changing the reader from *Armed* to *Disarmed* and back (i.e. reverse direction) is referred to hereinafter as "rearming". The term "arming" should be understood here as the action effecting a switch into the *Armed* mode, whereas the term "disarming" a switch into the *Disarmed* mode.



Reader rearming operation can be done by TOGGLE or TOGGLE LTD users. The

action needed by a TOGGLE user to rearm the reader is to read twice the TOGGLE card or to enter twice the TOGGLE PIN code — however, when the reader operates with the *Card and PIN* mode, user needs to do both things, read a card and enter a PIN code. TOGGLE LTD users may arm/disarm a reader simply by a single use of their identification tag (card, PIN or both when *Card+PIN* option is active).

Note: If the reader operates with an input line configured to option **Arming Disabled**, then the arming of a reader can be carried out providing that the input configured as **Arming Disabled** is not triggered, when these input is triggered (active) every attempt to arm a reader will be rejected. The condition of **Arming Disabled** input does not affects disarming of a reader.



6.5.1. Examples

Example 1: Rearm the reader by presenting a TOGGLE user card.



- Read your TOGGLE user card
- Once accepted the reader grants you access and its LED SYSTEM  starts blinking
- With the LED SYSTEM  blinking, once more present your TOGGLE card
- The reader changes its arming state (the LED STATUS  will change color)

Note: If the option **Access disabled when reader armed** is enabled and the reader is in *Armed* mode, then in order to unlock a door first you will have to switch the reader to *Disarmed* state (e.g. by presenting twice the TOGGLE card). Once the reader is in *Disarmed* mode you may use any valid identifier to unlock a door.

Example 2: Rearm the reader by entering a TOGGLE user PIN code.

- Key in the TOGGLE PIN code, use [#] key to mark an end of a PIN
- Once accepted the reader grants you access and its LED SYSTEM  starts blinking
- With the LED SYSTEM  blinking, once again enter a TOGGLE PIN
- The reader changes its arming state from *Armed* to *Disarmed* or vice versa (LED STATUS  will change color)

Example 3: Rearm the reader when the *Card and PIN* mode is enabled.

- Present your TOGGLE user card to the reader then key in the TOGGLE user PIN
- Once accepted, the reader grants you access and its LED SYSTEM  starts blinking
- With the LED SYSTEM  blinking, once more present your TOGGLE card and then enter a PIN
- The reader changes its arming state from *Armed* to *Disarmed* or vice versa (the LED STATUS  will change color)

6.6. Unlocking a door

In order to unlock the door user is required to enter his identifier (card and/or PIN). Whenever this happens, reader activates its LED SYSTEM  and generates short confirmation beep. After successful identification reader unlocks a door for **Door**

unlock time.

Note: The LED OPEN  is activated for the entire time when door remains unlocked. When access to the room is denied, reader generates a long continues beep.

The access to a room can be denied in following situations:

- When the identifier is not valid (unknown)
- When reader operates in *Armed* mode and the option **Access disabled when reader armed** is active
- When the identifier is a TOGGLE LTD type
- When the identification doesn't comply with the actual *Identification Mode* valid on the reader (e.g. when *Card and PIN* mode was set on the unit but user presented only card)

With option **Access disabled when reader armed** the TOGGLE or TOGGLE LTD users may use their identifiers (card, PIN or both when *Card and PIN* mode is active) to switch reader from *Armed* to *Disarmed* mode thus enabling NORMAL users to unlock a door, alternatively they can switch reader from *Disarmed* to *Armed* mode in order to disable unlocking of a door.

6.7. Operation with XM-2 I/O extension module

In *Full stand-alone mode* the PRT32 requires connection to an external XM-2 I/O extension module. Each input and output of the XM-2 can be programmed on the same basis as internal inputs and outputs of a reader. The XM-2 should be connected to the reader's CLK and DTA lines and should have address set to ID=5. The maximum distance between a reader and the XM-2 extension module is limited to 150 m.

6.8. Operation with the external PRT series reader

In *Full stand-alone mode* the PRT32 may optionally operate with the second PRT series reader. In such a case the main reader is called *primary reader* while the second one is called *secondary* reader. If used, the system with two readers enables two-way door control. The secondary reader should be connected to the primary reader through CLK and DTA lines and must be configured for *RACS operating mode* with address ID=0. The maximum distance between primary and secondary PRT reader is limited to 150 m.

Note: When the PRT32 reader operates with second access reader, the LED indications on a secondary unit mimics (follows) the LEDs on primary reader.

6.9. Door Bell function

Although the PRT32 is not equipped with any special functional key which would be solely dedicated to operate as a door bell button it offers an alternative mechanism. In order to trigger a **Door Bell** output user must press [#] key for more then 2s. The indication of a door bell is accompanied by continuous sound generated by the internal buzzer.

Note: In PRT32 the long press of [#] key is treated as Door Bell button while the use of [#] key which follows digits of a PIN code is used to mark the end of a PIN code.



6.10. Alarms

The PRT32 reader can detect and indicate following type of alarms:

- *Forced Entry*
- *Prealarm*
- *Door Ajar*

Forced Entry and *Door Ajar* alarms will occur only if the reader operates with a **Door Contact**. The alarm indication is carried out over the **Alarm Output** line and optionally accompanied by the internal buzzer (see option: **Door alarm indication on internal buzzer**). For each type of alarm the PRT32 uses different signal modulation of an output.

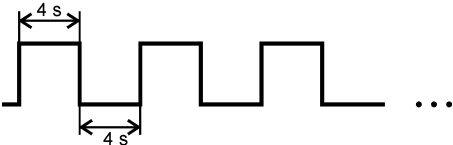
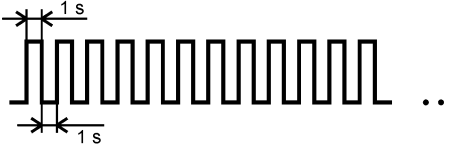
Alarm Indication Methods

Alarm type	Priority	Output modulation method	Alarm situation (event)
Forced Entry	High	By cycles with the following sequence: Active - 4 sec., Pause - 4 sec. 	A door was opened without use of a valid identifier.
Prealarm	Medium	By cycles with the following sequence: Active - 1 sec., Pause - 1 sec. 	Detection of 3 consecutive attempts of entering an unregistered (unknown) identifier.
Door Ajar	Low	By cycles with the following sequence: Active - 1 sec., Pause - 1 sec., Active - 1 sec., Pause - 5 sec. 	After access has been granted and door is left ajar for the period longer then time defined by C3C4 configuration parameters.

Note: The modulation methods are used for both, the **Door Alarm** output and for internal buzzer (if configured for alarm indication).

Alarm duration is last app. 3 minutes, regardless of the alarm type. Each alarm can be stopped by using any from of identifier registered in the reader. The *Door Ajar* alarm is also immediately stopped, once the door is closed. If more than one alarm is triggered, the reader indicates the alarm with the highest priority.

7. Programming

The programming steps which are required for PRT32 reader depends on the operating mode to which it was configured for. The PRT32 can not be programmed from PC, it can be only programmed manually from its keypad.

Note: The programming of a reader can be done on *primary* reader only.

7.1. Preparing the reader for Online mode

If the unit is dedicated for *Online* mode the only one programming step which is required is setting the reader's operating mode.





7.2. Preparing the reader for Offline mode







If the unit is dedicated for *Offline* mode the installer must perform four programming steps:



- Setting the reader to required *Offline* mode (either *Full* or *Simple stand-alone mode*)
- Programming the MASTER and INSTALLER users
- Configuring the reader for specific installation scenario (*Installer Programming*)
- Programming cards and/or PINs (*User Programming*)

7.3. Setting the reader's operating mode

The settings of the reader operating mode is achieved on programming jumpers. The factory new reader is pre-configured for **RACS Online** operation mode with address **ID=0**.

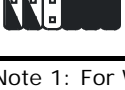
Jumper settings	Operating mode	Description
	Offline mode, <i>Simple Stand-alone mode</i>	The reader operates in the <i>Stand-alone mode</i> , the CLK and DTA lines serve as ordinary I/O lines.
	Offline mode, <i>Full Stand-alone mode</i>	The reader operates in the <i>Stand-alone mode</i> , the CLK and DTA lines are used for communication with remote XM-2 I/O and optional (secondary) PRT reader.
	Online mode, RACS communication interface, address ID=0	The reader operates as a slave reader connected to a host controller that requires <i>RACS</i> data transmission format.
	Online mode RACS communication interface, address ID=1	

	Online mode, RACS communication interface, address ID=2	
	Online mode, RACS communication interface, address ID=3.	
	Online mode, <i>Magstripe</i> communication interface	The reader operates as a slave reader connected to a host controller that requires <i>Magstripe</i> data transmission format.
	Online mode, 26 bit <i>Wiegand</i> communication interface	The reader operates as a slave reader connected to a host controller that requires 26/34/42/66 bit <i>Wiegand</i> data transmission format.
	Online mode 34 bit <i>Wiegand</i> communication interface	
	Online mode, 42 bit <i>Wiegand</i> communication interface	
	Online mode, 66 bit <i>Wiegand</i> communication interface	
<p>Note 1: For Wiegand data interfaces the JP1 and JP2 jumpers are used to specify the method of PIN code transmission (for coding details see table below). In RACS data formats the JP1 and JP2 jumpers are used to specify reader's address (ID number).</p> <p>Note 2: For both, Simple and Full stand-alone modes, the JP1 jumper is used to enter the <i>Memory Reset</i> procedure.</p>		

JP1 and JP2	Description	Details
	1-10 digits long PIN, transmitted in BCD format	Each key pressed is buffered in reader's memory, with a press of a [#] key reader transmits entire PIN code. The PIN code is transmitted as a BCD coded number.
	1-12 digits PIN, transmitted in binary format	Each key pressed is buffered in reader's memory, with a press of a [#] key reader transmits entire PIN code. The PIN code is transmitted as a binary number.
	Each key pressed is transmitted separately with two control bits	Each key pressed is immediately transmitted to the host controller as a sequence of 6 bits (EXXXXP) where XXXX represents the code of the pressed key supplemented by two control bits (E and P). The E represents the even bit calculated from the first half of a transmitted code where P represents the parity of a second half of the bit stream. This format is compatible with HID 5355 series readers, option: <i>With Parity</i> .

	<p>Each key pressed is transmitted separately, no control bits added</p>	<p>Each key pressed is immediately transmitted to the host controller as a sequence of 4 bits (XXXX) which represent the code of the pressed key, no control bits added. This format is compatible with HID 5355 series readers, option: <i>Without Parity</i>.</p>
<p>Note: The PIN code transmission options described in this table apply to 26/34/42/66bit Wiegand data formats only.</p>		

When the reader is set for *Stand-alone* mode (*Offline*), installer must program to a reader two special cards; MASTER and INSTALLER and then enter the *Installer Programming* mode in order to make final configuration settings. The programming of the cards and PINs can be carried out in the *User Programming* mode.

Note: If you observe that after selection of a reader's operation mode or after power up of a unit, the LED SYSTEM  is on and accompanied with acoustic signal it means that the contents of reader's memory is corrupted or the MASTER/INSTALLER card are not programmed. In this case you must perform the full *Memory Reset* and completely re-program a reader.

7.4. Memory Reset - programming MASTER and INSTALLER users

The *Memory Reset* erases all cards and PINs including MASTER and INSTALLER users. Also, it causes the reader restores the factory-shipped default settings. The *Memory Reset* has practical sense for *Offline* modes only, it does not affect the unit if it is configured for *Online* mode.

To perform Memory Reset follow these steps:

- Power down the unit
- Check the jumpers and assure that reader is configured to either *Full stand-alone* or *Simple stand-alone* mode, if not select appropriate standalone mode
- Once configured to standalone mode place jumper on JP1 contacts
- Restart the reader (switch power off and on), reader will generate a continuous beep
- Wait until the LED OPEN  starts flashing
- Remove jumper from JP1 contacts
- Enter new MASTER PIN (3-6 digits) or skip this step and go to next one
- Present any card to the reader — this card becomes a new MASTER card or press [#] and go to the next step
- Enter new INSTALLER PIN (3-6 digits) or skip this step and go to next one
- Present another (second) card to the reader — this card becomes a new INSTALLER card or press [#] and go to the next step
- Once the previous step has been completed reader automatically ends the *Memory Reset* and enters the *Armed* mode



7.4.1. Factory default settings

Once the *Memory Reset* is completed the reader restores the following factory-shipped default settings:

- **Door unlock time:** 4 sec.

- **Door open timeout:** 12 sec.
- Line IN1 on the reader: **Door Contact** input
- Line IN1 on the XM-2 module: **Exit Button** input
- Line IN2 on the XM-2 module: **Arming Disabled** input
- CLK or REL1 line function: **Door Lock** output
- DTA or REL2 line function: **Disarmed Mode** output
- User identification mode on the primary reader: **Card or PIN**
- User identification mode on the secondary reader: **Card or PIN**
- Option: **Door alarm indication on internal buzzer**, option OFF
- Option: **Access disabled when reader armed**, option OFF

7.5. Installer Programming mode

Use this mode to configure various functionalities of the PRT32 reader. You can enter it by presenting your INSTALLER card to the unit or entering the INSTALER PIN code. Once in this mode the LED OPEN  is on and LED STATUS  is green. The reader placed in this mode waits for the installer to sequentially enter thirteen parameters labeled C1 to C13. After entering the last one the reader saves all entered data, then exits the programming mode and returns to the operating mode it was in before entering *Installer Programming*.

Note: If you don't press any key within 20 s time, reader will automatically leave the programming mode.

Depending on the operation mode selected for the reader (either *Simple Stand-alone Mode* or *Full Stand-alone mode*), the configuration digits C5 and C6 may have different effects: for *Simple Stand-alone mode* they configure the reader's CLK and DTA internal lines, while for *Full Stand-alone mode* they program functions of the REL1 and REL2 relay outputs located on XM-2 I/O extension module.

Note: The IN1 located on the reader always operates as an input. The reader's CLK and DTA lines can be used either as inputs or outputs. Still, the REL1 and REL 2 lines may function only as outputs. Also, the IN1 and IN2 on the XM-2 operate as inputs only. If you try to program the REL1 and REL2 lines to some input function, they will not work at all.



Configuration Parameters in the Installer Programming mode

Parameter	Value	Description
C1 and C2	00–99	The C1 and C2 digits define time for which the reader unlocks a controlled door. The C1C2 digits are called Door unlock time , the C1C2 time is defined in seconds. When C1C2=00, reader unlocks a door for unlimited time, till a moment when reader grants access again (this scenario is also called: <i>Latch operation</i>). Also the C1C2=00 setting disables the <i>Door Ajar</i> alarm.
C3 and C4	00–99	The C3 and C4 digits define Door open timeout in seconds. Once opened, door should be closed within this timeout, if not the Door Ajar alarm will arise. The Door open timeout starts with the moment when Door unlock time is elapsed. If reader is not connected to door contact sensor then the Door open timeout is ignored.

C5	0 – 7	<p>Function settings for the REL1 output on the XM-2 module (when in <i>Full stand-alone</i> mode) or for the CLK line (when in <i>Simple stand-alone</i> mode):</p> <p>[0] – Line off, line is disabled</p> <p>[1] – Door Contact (input), line shorted to supply minus indicates that corresponding door is closed</p> <p>[2] – Exit Button (momentary input), shorting the line with supply minus unlocks a door for time defined by Door unlock time</p> <p>[3] – Arming Disabled (input), when line is shorted with supply minus reader will reject any attempt to go into <i>Armed</i> mode</p> <p>[4] – Door Lock (output), output controls the door releasing device (an electric lock or electric strike).</p> <p>[5] – Disarmed Mode (output), line is triggered for the entire time when reader is <i>Disarmed</i></p> <p>[6] – Door Alarm (output), line is used to indicate alarm, output is modulated according to a detected alarm type, when more then one alarm exist output indicates alarm with a highest priority.</p> <p>[7] – Door Bell (output), whenever the door bell event occurs this output goes on for approx. 5 seconds.</p>
C6	0 – 7	Function settings for the REL2 output on the XM-2 module or for the DTA line, assignments as above.
C7	0 – 3	<p>Function settings for the IN1 line on the reader:</p> <p>[0] – Line off, line is disabled</p> <p>[1] – Door Contact (input), line shorted to supply minus indicates that corresponding door is closed</p> <p>[2] – Exit button (momentary input), shorting the line with supply minus unlocks a door for time defined by Door unlock time</p> <p>[3] – Arming Disabled (input), when line is shorted with supply minus reader will reject any attempt to go into <i>Armed</i> mode</p>
C8	0 – 3	Function settings for the IN1 line on the XM-2 module – assignments as for C7.
C9	0 – 3	Function settings for the IN2 line on the XM-2 module – assignments as for C7.
C10	0 – 1	<p>The <i>Identification Mode</i> for primary (main) reader:</p> <p>[0] - Card or PIN</p> <p>[1] - Card and PIN</p>
C11	0 – 1	<p>The <i>Identification Mode</i> for secondary (auxiliary) reader:</p> <p>[0] - Card or PIN</p> <p>[1] - Card and PIN</p>
C12	0 – 1	<p>Option: Door alarm indication on internal buzzer</p> <p>[0] – Disabled</p> <p>[1] – Enabled</p>
C13	0 – 1	<p>Option: Access disabled when reader armed</p> <p>[0] – Disabled</p> <p>[1] – Enabled</p>

Note: Depending of the selected reader operating mode (either *Full stand-alone* or *Simple stand-alone*) the parameters C5 and C6 may refer to REL1 and REL2 output lines on remote XM-2 I/O extension module or to CLK and DTA lines located on a reader.

Example: Configuring the reader in the Installer Programming mode



Read your INSTALLER card once, the reader enters *Installer Programming* mode (the LED OPEN  is on and the LED STATUS  lights in green) then enter following sequence of 13 digits: 0206451230001. Those digits configure the reader for following options:

- **Door unlock time:** 02 sec.
- **Door open timeout:** 06 sec.
- CLK or REL1 line function: **Door lock** output
- DTA or REL2 line function: **Disarmed Mode** output
- Line IN1 on the reader: **Door Contact** input
- Line IN1 on the XM-2 module: **Exit Button** input
- Line IN2 on the XM-2 module: **Arming Disabled** input
- *Identification Mode* on primary reader: **Card or PIN**
- *Identification Mode* on secondary reader: **Card or PIN**
- Option **Door alarm indication on internal buzzer** disabled
- Option: **Access disabled when reader armed** disabled

Last step completes the programming and the reader automatically leaves *Installer Programming* mode and returns to the operating mode (either *Armed* or *Disarmed*) in which it was in before entering *Installer Programming*.

Note: *Installer Programming* can be accessed only if the reader was earlier configured for either *Full Stand-alone* or *Simple Stand-alone* mode.

7.6. User Programming mode

The *User Programming* mode is dedicated to manage users registered in the reader (add and delete cards and PINs). To enter this mode read the MASTER card or enter MASTER PIN code. Once in *User Programming* mode, the LED OPEN  is on and the LED STATUS  lights in red.

In the *User Programming* mode you have 12 programming commands to choose from. Once you enter any programming function the LED SYSTEM  starts flashing and it keeps flashing till command sequence has been successfully completed. If the reader receives no valid entries for more than 20 sec. (between the successive steps of the command sequence), it will automatically end the command sequence. However, it will still remain in *User Programming* mode so that you may return to any user programming command or you may press [#] to exit this programming mode, alternatively you may wait ~150 sec. for the reader to leave *User Programming* mode automatically.

7.6.1. User programming commands

Note: Any attempt to program an already registered card or PIN will be indicated as a programming error.

[1][PIN][#] – Add single NORMAL user with a PIN

The new NORMAL user is stored in a first unoccupied memory location with given PIN, his ID number is unknown.

[2][Card 1][Card 2]...[Card N] – Add multiple NORMAL users with cards

The reader indicates each successful card reading with an acoustic prompt signal for the next one to follow. This function will be ended automatically if no card is presented within 20 sec. from the previous card presentation or you can end it earlier by pressing the [#] mark. Note, that the new card users added with this function are stored in unoccupied (free) location of the memory and their IDs are unknown.

[3][ID][PIN][#][Card] – Add single NORMAL user with an ID, PIN and card

The new NORMAL user is registered in the memory at the location indicated by his ID number (ID=000–119). Both, the entered PIN code and presented proximity card are assigned to him. When you want to program only PIN enter:

[3][ID][PIN][#][#], when you want to program only card enter: [3][ID][#][Card].

[4][PIN][#] – Add single TOGGLE user with a PIN only

The new TOGGLE user is stored in a first unoccupied memory location with entered PIN, his ID number is unknown.

[*][4][PIN][#] – Add single TOGGLE LTD user with a PIN only

The new TOGGLE LTD user is stored in a first unoccupied memory location with entered PIN, his ID number is unknown.

[5][Card 1][Card 2]...[Card N] – Add multiple TOGGLE users with cards

The reader indicates each successful reading of the presented card with an acoustic prompt signal for the next one to follow. This function will be ended automatically if no card is presented within 20 sec. from the previous card presentation or you can end it manually by pressing [#]. Note, that the new card users added with this function are stored in unoccupied (free) locations of the memory and their IDs are unknown.

[*][5][Card 1][Card 2]...[Card N] – Add multiple TOGGLE LTD users with cards

The reader indicates each successful reading of the presented card with an acoustic prompt signal for the next one to follow. This function will be ended automatically if no card is presented within 20 sec. from the previous card presentation or you can end it manually by pressing [#]. Note, that the new users added with this function are stored in unoccupied (free) locations of the memory and their IDs are unknown.

[6][ID][PIN][#][Card] – Add single TOGGLE user with an ID, PIN and card

The new TOGGLE user is registered in the memory at the location indicated by ID number (ID = 000–119). Both, the entered PIN code and the presented proximity card are assigned to him. When you want to program only PIN enter:

[6][ID][PIN][#][#], when you want to program only card enter: [6][ID][#][Card].

[*][6][ID][PIN][#][Card] – Add single TOGGLE LTD user with an ID, PIN and card

The new TOGGLE LTD user is registered in the memory at the location indicated by ID number (ID=000–119). Both the entered PIN and the presented proximity card are assigned to him. When you want to program only PIN enter:

[*][6][ID][PIN][#][#], when you want to program only card enter:

[*][6][ID][#][Card].

[7][PIN][#] – Delete a PIN

The reader searches its memory for the given PIN. Once successful it removes it from the memory, the location previously occupied by this PIN is released. This command removes only PIN, if the user have card he still can use it.

[8][Card] – Delete a card

The reader searches its memory for the presented card. Once successful it removes it from the memory, the location previously occupied by this card is released. This command removed only card , if the user have PIN he still can use it.

[9][ID] – Delete a user with entered ID

The user with entered ID is deleted (both his card and his PIN are removed), a new user can be programmed to use this ID index.

[*][0] – Delete all users

Reader deletes all users (cards and PINs) so that all IDs are released and can be programmed anew.



[#] – Exit User Programming mode

After exit from the *User Programming* mode the reader returns to the operation mode it was in before entering it (reader returns either to *Armed* or *Disarmed* mode).

Note: Each user ID index consists always of three digits to form ID numbers ranging 000–119. In case you assign a new user the ID that is already occupied by some other user, this will remove the older one from the memory.

7.6.2. Programming examples



Example 1: Add a new TOGGLE LTD user with a card - programming sequence: [*][5][Card][#] or [*][5][Card][Wait ~20s]

- Read your MASTER card
- The reader enters *User Programming* mode (LED OPEN  is on and its LED STATUS  is on and red)
- Press [*]
- Press [5]
- LED SYSTEM  starts flashing
- Present a card which you want assign for a new user
- Press [#]
- Command is completed

The reader has completed programming function, however, it has not left *User Programming* mode so that now you may use your next desired programming command.

Example 2: Delete a user with ID=45 - programming sequence:

[9][0][4][5][#]

- Read your MASTER card
- The reader enters *User Programming* mode (LED OPEN  is on and its LED STATUS  is on and red)
- Press [9]
- LED SYSTEM  starts flashing
- Press [0]
- Press [4]
- Press [5]
- Press [#]
- Command is completed



The reader deletes the user with ID=45 from its memory, however, it remains in *User Programming* mode, so that you may use your next desired programming command.

8. Acoustic and optical signals in Offline mode

Acoustic signals in Offline (stand-alone) mode

Signal	Symbol	Description
One long signal	-	Error - unknown identifier, access denied.
Two long signals	- -	Attempt to assign the same function for two different input lines.
Three short beeps	* * *	Command successfully completed (OK signal).
Two short beeps	* *	Prompt signal, the reader is waiting for the next part of the command to be entered. This signal is intended to encourage the programmer to proceed with next programming steps.
One long signal continuously repeated	- - - - - ... and so on	Memory contents corrupted or either MASTER or INSTALLER card not programmed - <i>Memory Reset</i> is necessary. This signal is accompanied by the steady lit LED SYSTEM  .
Legend: - single long audible signal, * single short audible signal (beep)		

LED indications in Offline (Stand-alone) operation mode

LED STATUS 	LED OPEN 	LED SYSTEM 	Description
Green	—	—	The reader is in Disarmed state now.
Red	—	—	The reader is in Armed state now.
Red	Green	—	The reader is in <i>User Programming</i> mode.

Green	Green	—	The reader is in <i>Installer Programming</i> mode.
—	—	Orange Flashing	Waiting for the user to enter the next part of the command or programming function.
—	—	Orange, (single flash)	A user identifier (Card/PIN) has been entered.
—	Green	—	The door lock is activated, this LED remains on as long as the door is unlocked.
—	Green flashing	—	The reader is waiting for a user to enter his identifier once again.
—	—	Steady	The reader has detected some problem (memory contents is corrupted or the MASTER/INSTALLER cards are not programmed).

9. Installation guidelines

- Any EM 125 kHz UNIQUE standard card can be programmed as a MASTER or INSTALLER card, manufacturer of the reader does not supply the unit with any cards.
- When lost or stolen a new MASTER and INSTALLER cards can be reprogrammed to a reader.
- When the reader is configured for *Online* operation, the programming of MASTER and INSTALLER users can be skipped.
- A new factory delivered unit is configured for **RACS Online mode** with address ID=0
- Disconnect power supply before making any electrical connections.
- For installations on a metal surface, place a non-metallic min. 10 mm thick spacer (a plastic/plaster plate etc.) between the reader and the supporting structure.
- For installations with two readers to be mounted on the opposite sides of the same wall and aligned along the same geometrical axis, place a metal plate between them and make sure none of them has direct contact with it (allow min. 10 mm space).
- For best results mount the proximity readers at least 0.5 m apart.
- With its relatively weak electromagnetic field generation, the reader should not cause any harmful interference to operation of other equipment. However, its card reading performance can be affected by other interference generating devices, esp. radio waves emitting equipment or CRT computer monitors.
- If card reading performance of the reader deteriorates (e.g. reduced reading range or incorrect readings) consider reinstallation in a new location.
- Always connect a general purpose silicon diode (e.g. 1N4007) in parallel to a door lock. Connect diode close to the lock.

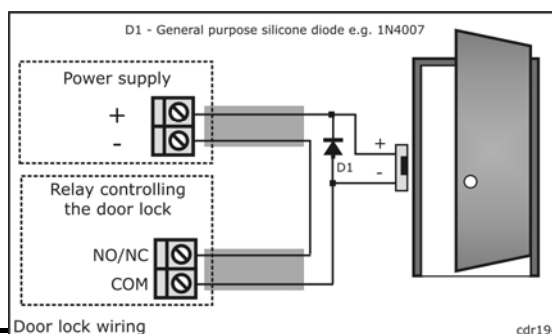

10. Appendix

Connection Terminals

Connection terminal	Offline mode		Online mode (unit connected to host ACU)
	Simple Stand-alone mode	Full Stand-alone mode	
+12V	Supply input plus.		
GND	Supply input minus.		
CLK	Can be configured as an input or output.	CLOCK communication line.	DATA 0 line for <i>Wiegand</i> formats CLOCK for <i>Magstripe</i> and RACS formats.
DTA	Can be configured as an input or output.	DATA communication line.	DATA 1 line for <i>Wiegand</i> formats DATA for <i>Magstripe</i> and RACS formats.
IN1	Input line, can be configured to several available functions).		In <i>Wiegand</i> and <i>Magstripe</i> formats, the IN1 line activated by shorting it with the supply minus. When IN1 is triggered it turns the LED OPEN  to on and also activate acoustic signal on the internal buzzer.
TAMP	Isolated, tamper switch contacts, when case is closed contacts are shorted.		

Technical Specification

Input voltage	10...15 VDC
Current consumption	Avg. 60 mA
Anti-sabotage protection (Tamper)	NC contact, 50mA/24V
Reading distance	Up to 12 cm for ISO cards (depends on cards).
Proximity cards	EM UNIQUE 125 kHz, ASK modulation, 64 bits (compatible with EM4100/4102).
Communication distance	Between ACU and PRT reader in ONLINE mode: max. 150 m. Between main PRT reader and second PRT reader: max. 150 m. Between main PRT reader and XM-2 extension module: max. 150 m.
Environmental class (according to EN 50131-1)	Class I, Indoor, temperature: +5°C- +40°C, relative humidity: 10 to 95% (non-condensing).
Ingress protection	IP 30
Dimensions	H105 X W105 X D31 mm
Weight	~140 g
Approvals	CE

Ordering Codes

PRT32	RFID/PIN reader, grey color.
RM-2	Relay module, the RM-2 offers two relays with one NO/NC contact 1.5A/24V rated, relay contacts are protected by over-voltage components. Module is delivered with plastic box.
RM-2 Brd	The RM-2 PCB module without casing.
XM-2	I/O addressable extension module, digital communication with host reader, two NO/NC inputs and two relay outputs, each relay offers one NO/NC contact 1.5A/24V rated. Relay contacts are protected by over-voltage components. Module is delivered with plastic box.
XM-2 Brd	The XM-2 PCB module without casing.

Product History

Hardware	Firmware	Date	Description
PRT32 v1.0	71.00	18/04/05	The initial product version.
PRT32 v1.0	72.00	05/07/05	Error indications changed. Card code errors when reading some type of cards corrected.
PRT32 v1.0	73.00	21/04/06	<ol style="list-style-type: none"> 1. LED SYSTEM  doesn't react a single key press. This modifications refers to Wiegand modes which are configured for transmission of a single key press (option: X=3 and X=4). 2. The transmission of F1 and F2 keys in Wiegand and Magstripe formats added.
PRT32 v1.0	74.7	05/10/2006	Definition of MASTER and INSTALLER identifiers modified. In this version, both, MASTER and INSTALLER may have card and/or PIN.

Contact information:
Roger sp. j.
82-416 Gościszewo
Gościszewo 59
Phone: 055 272 0132
Fax: 055 272 0133
e-mail: biuro@roger.pl

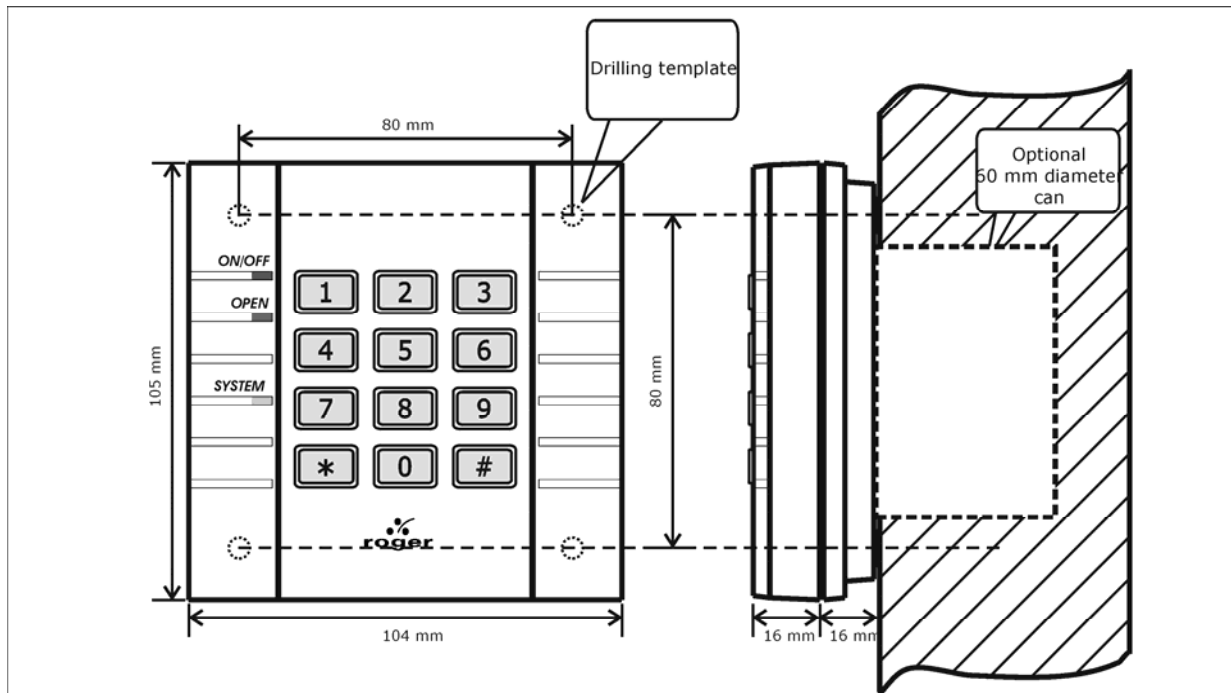

The front and side view of PRT32 terminal

Front cover
(self-adhesive)

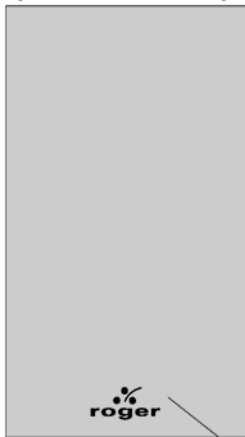

Apply on
free surface

PRT32 without keypad

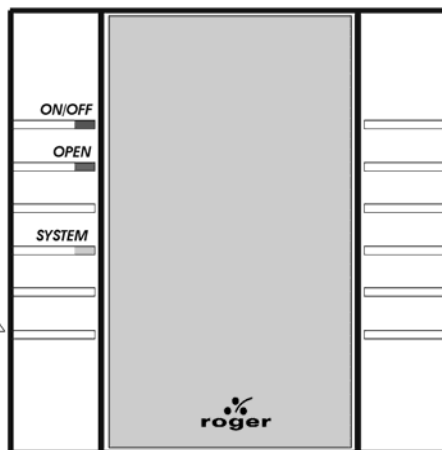

Silicone rubber
keypad

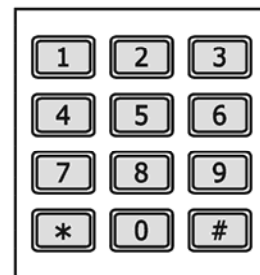

remove

If PIN-codes not required keypad can be removed and replaced with plastic self-adhesive cover.

Cdr103enp2

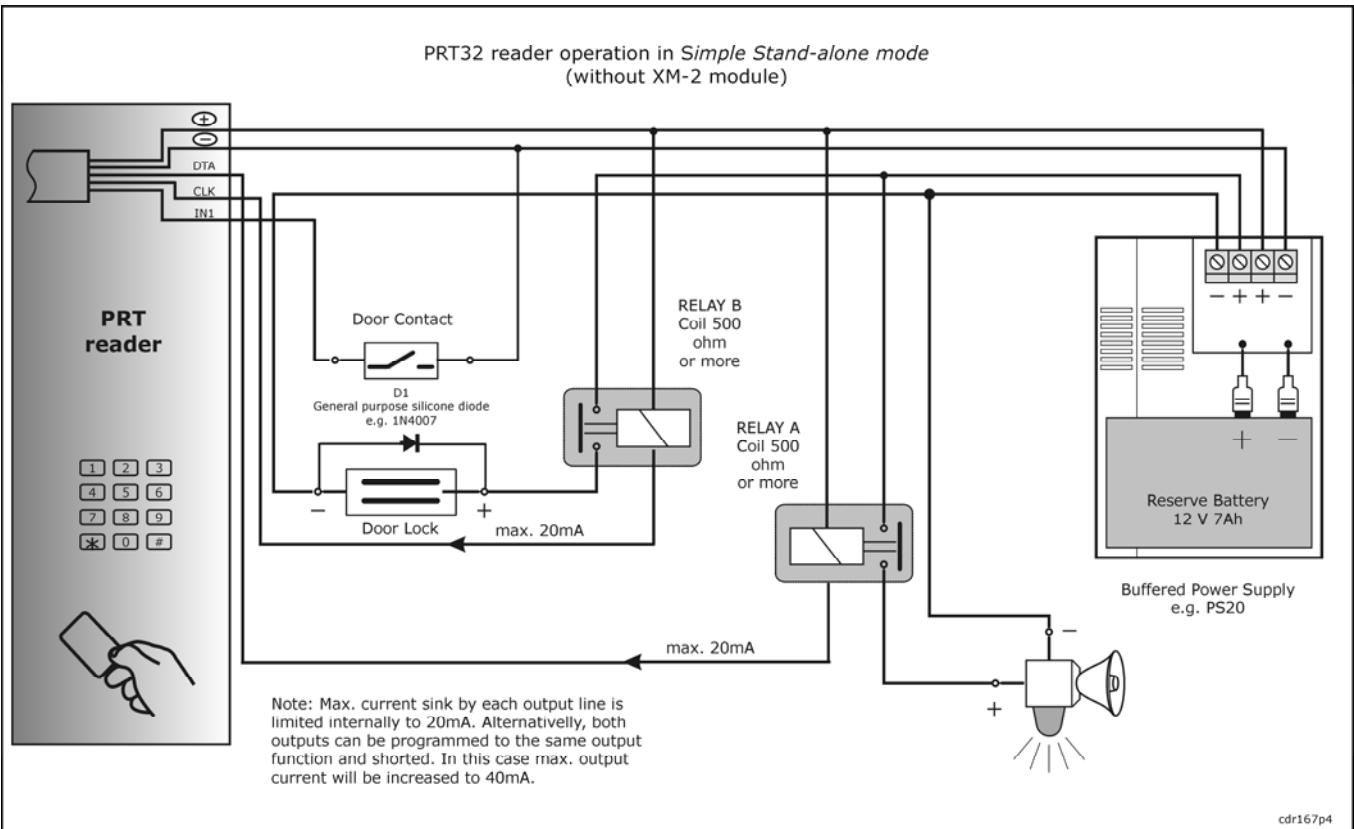
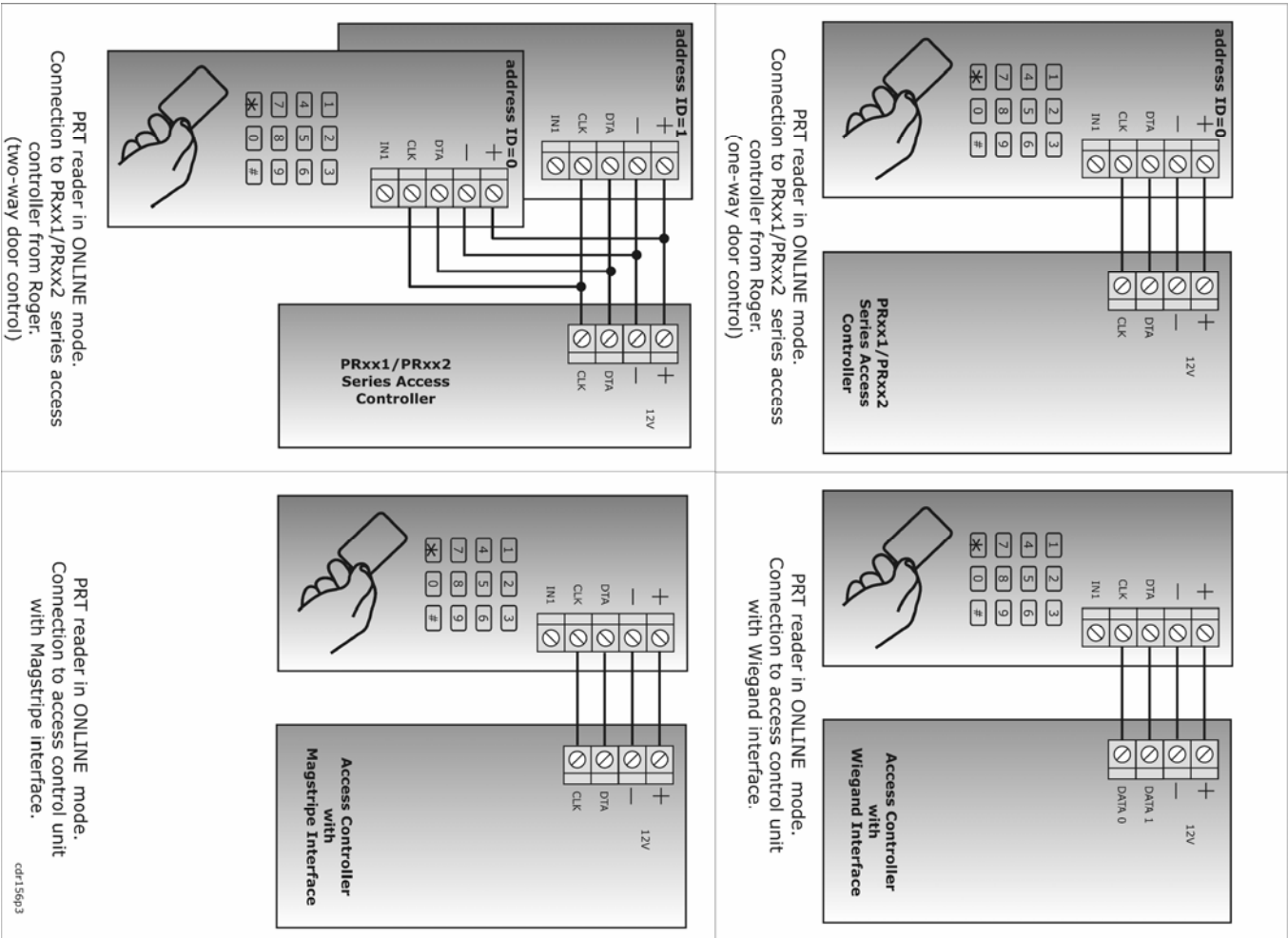

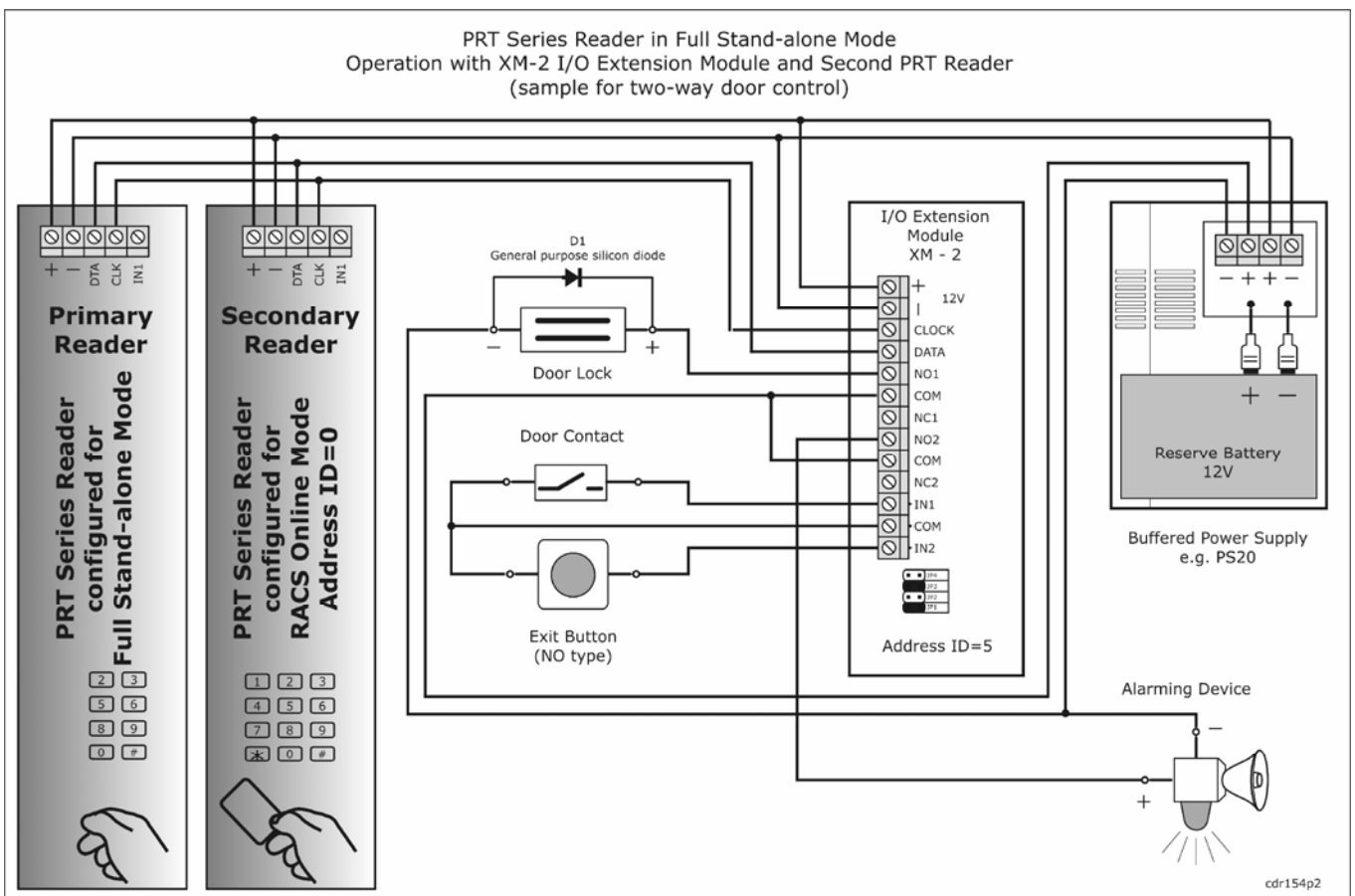
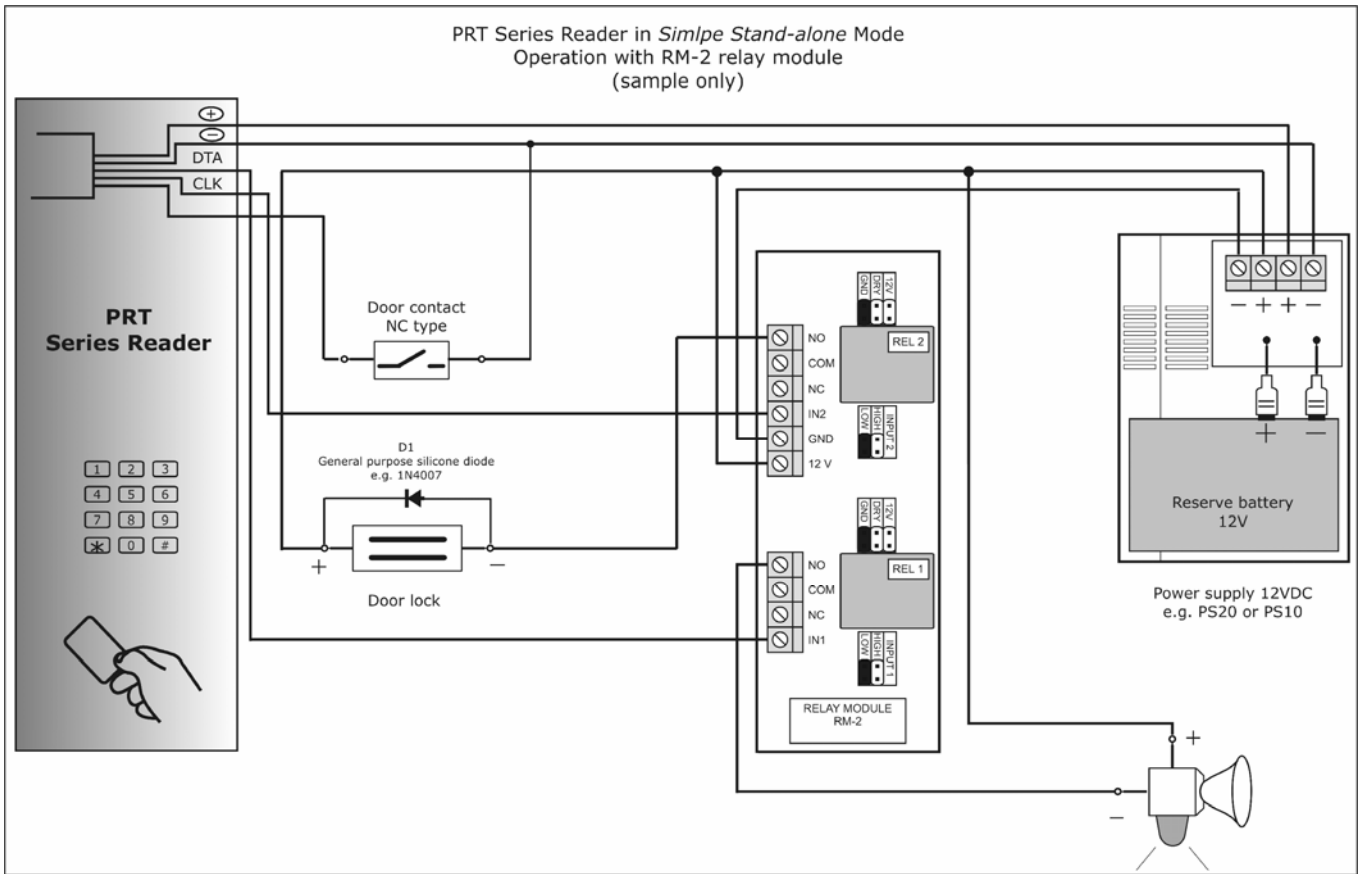

cdr154p2