

Prestige Compact IR

Passive Infrared Detector

INSTALLATION INSTRUCTIONS

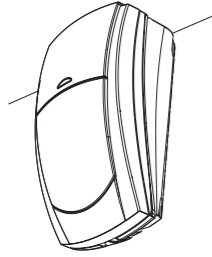

Texecom
www.texecom.com

INS 244-3

Ask your distributor today for the Texecom full colour Product Guide.

QUALITY ASSURANCE



A HALMA GROUP COMPANY

MADE IN ENGLAND



Certificate Number: FM 35285

WARRANTY

10 year replacement warranty.

The Prestige Compact IR is designed to detect the movement of an intruder and activate an alarm control panel. As the Prestige Compact IR is not a complete alarm system, but only a part thereof, Texecom cannot accept responsibility or liability for any damages whatsoever based on a claim that the Prestige Compact IR failed to function correctly.

All specifications are measured at 20°C (68°F). Due to our policy of continuous improvement Texecom reserves the right to change specification without prior notice.

Document Ref: PCIR/EU/1.0-3

© 2003-2006 Texecom Ltd

The Prestige Compact IR is protected by UK & International Registered Design. Registered Design Number: 3008617

1 PHYSICAL

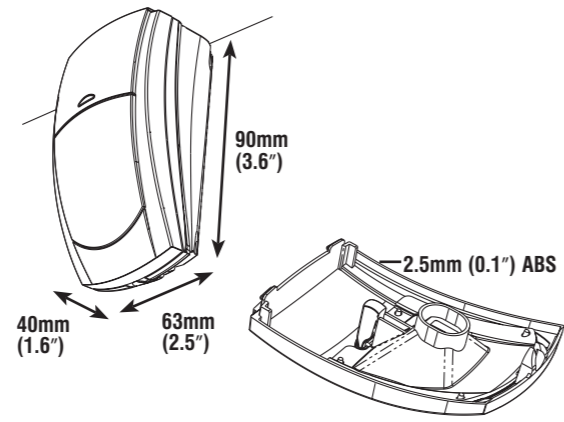

2 ENVIRONMENTAL

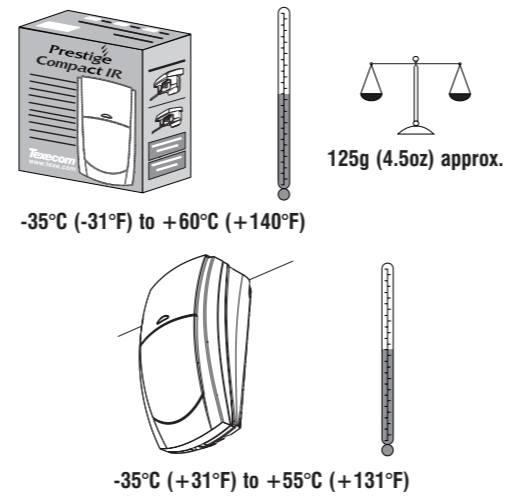

3 STANDARDS & APPROVALS

Alarm Standard:	EN 50131 Grade 2 Environmental Class II.
Detector Standard:	TS 50131-2-2 Grade 2 Environmental Class II.
EMC:	Independently certified to BS EN 50130-4 : 1996.
RF Immunity:	No false alarms from 80MHz to 1GHz at 10V/m. Complies with BS EN 61000-4-3 : 1997.
Electrostatic Discharge:	No false alarms up to 8kV. Complies with BS EN 61000-4-2 : 1995.
Fast Transient Immunity:	No false alarms up to ±4kV. Complies with BS EN 61000-4-4 : 1995.
High Energy Transient Immunity:	No false alarms up to ±1kV. Complies with BS EN 61000-4-5 : 1995.
Conducted RF Susceptibility:	No false alarms at 10Vrms. Complies with BS EN 61000-4-6 : 1996.
Conducted & Radiated Emissions:	Complies with EN 55022 Class B.

4

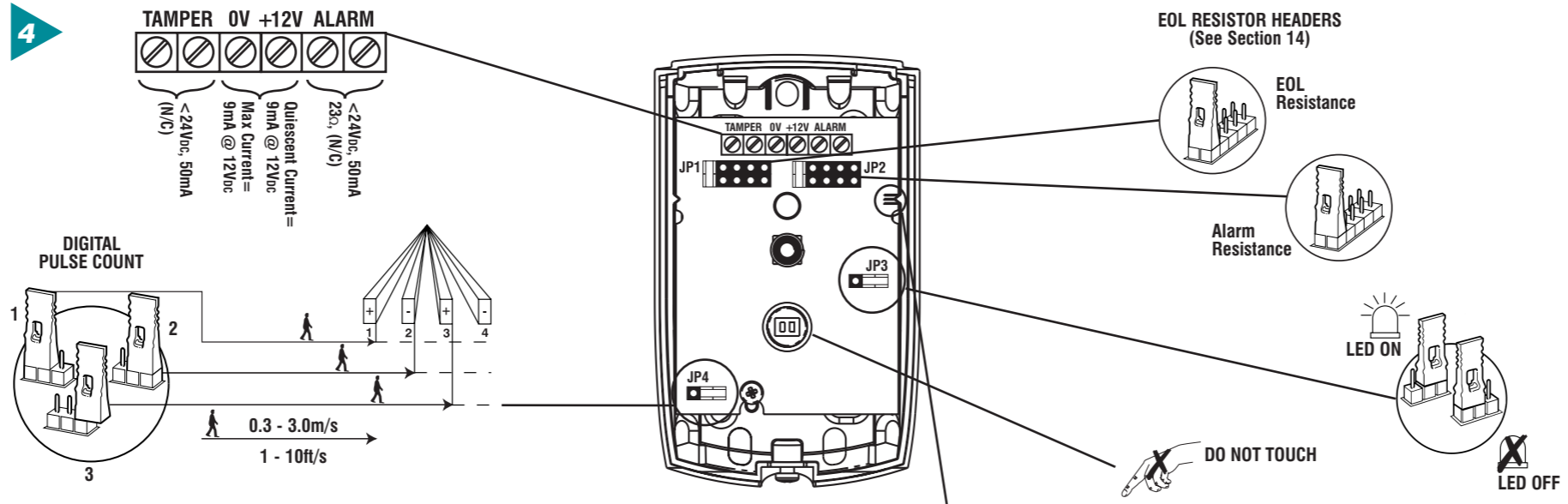

5 COVERAGE AND PICK-UP

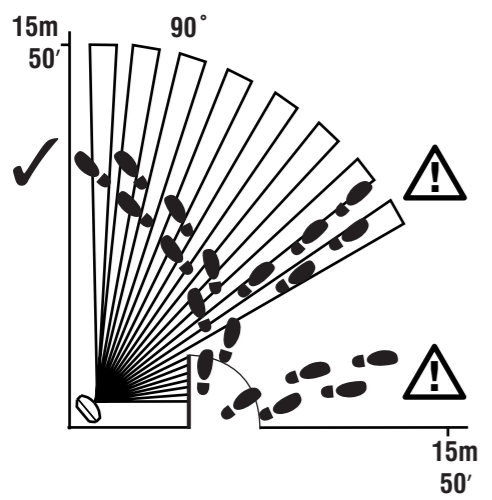

6 ANGLING THE DETECTOR

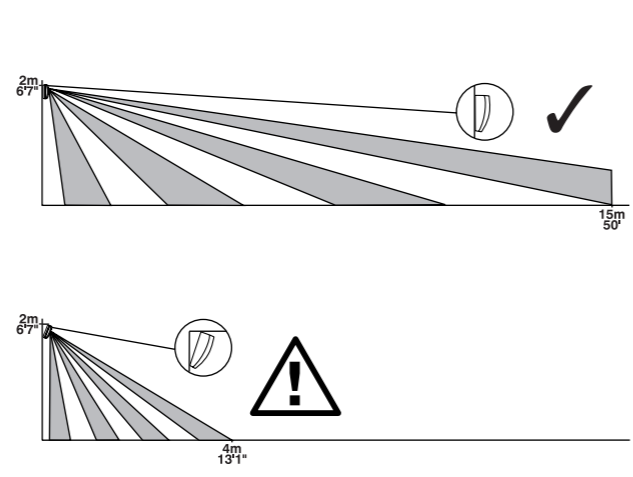

7 MOUNTING HEIGHT AND SETTINGS

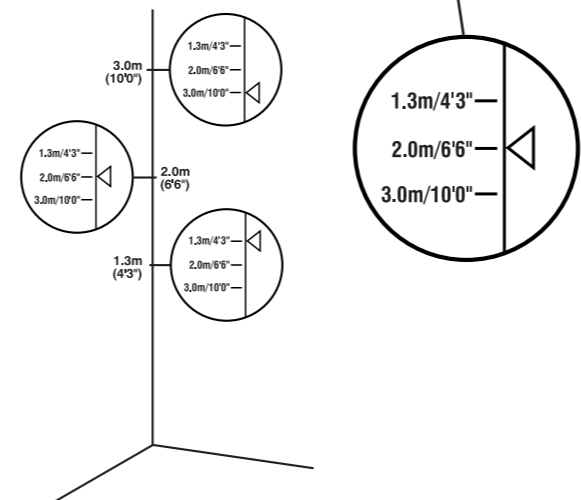

8 COVERAGE AT 2m

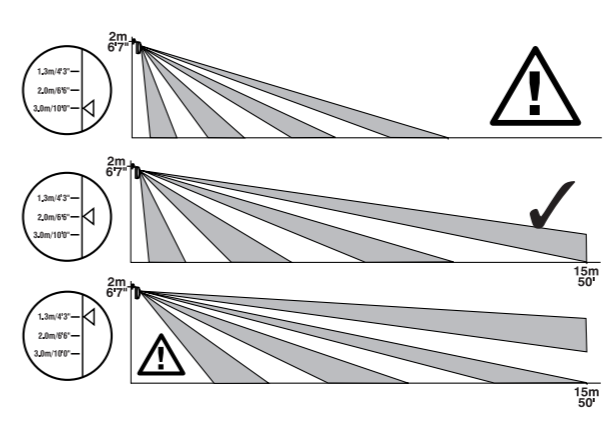

9 COVERAGE PATTERN VOLUMETRIC

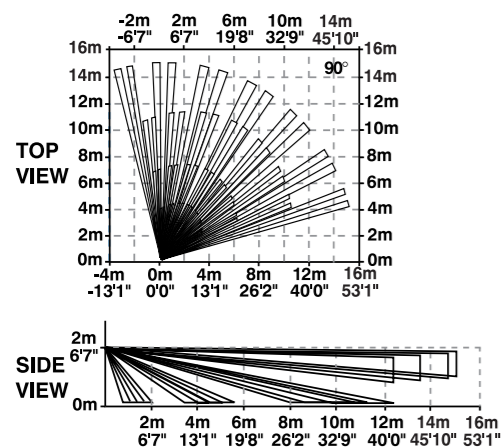

See Mounting Height Diagram (Section 7)

10 MOUNTING For indoor use only

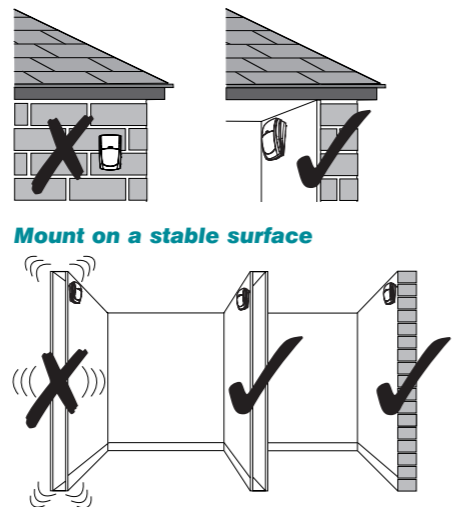

11 WIRING Do not run cable parallel to mains wiring

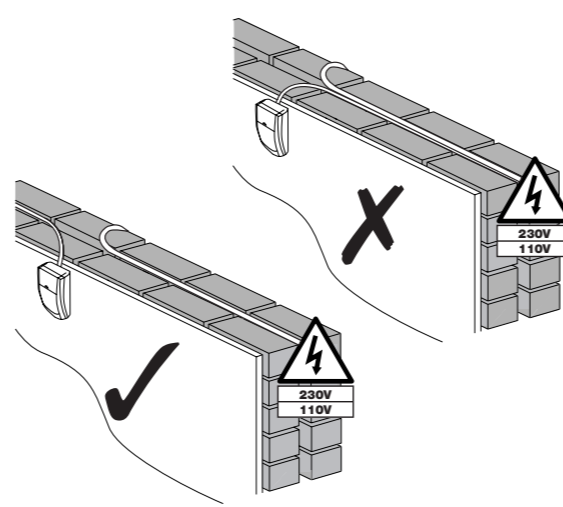

12 CHOOSING A LOCATION Avoid common false alarm sources

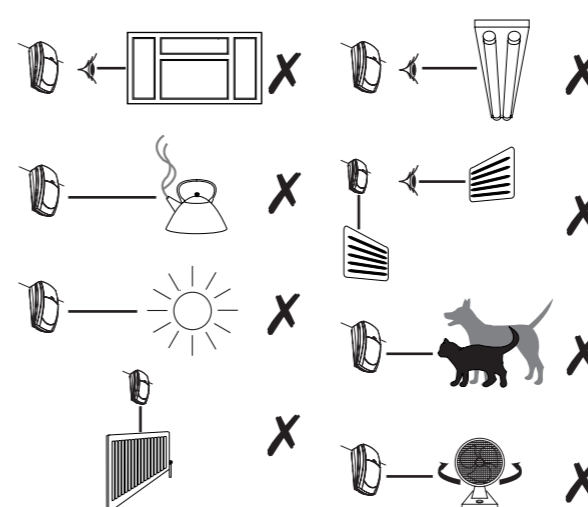

13 EOL RESISTOR JUMPER LINKS

The headers JP1 and JP2 (see Section 4) are used to select resistances for End-of-Line (EOL) wiring applications.

JP1 Selects the End-of-Line resistance. Equivalent to wiring a resistor of the selected value as shown.

JP2 Selects the resistance across the alarm relay. Equivalent to wiring a resistor of the selected value as shown.

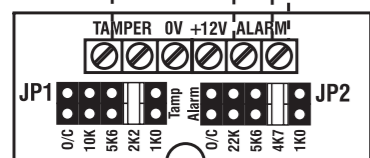

If EOL wiring is not used, the headers should be left in the default (O/C) position. If the required resistance values are not available, leave the headers in the O/C position and wire in external resistors as normal.

EOL Settings for Texecom Panels

	JP1	JP2
Veritas	10k	22k
Premier & Premier International	2k2	4k7

EXAMPLES OF EOL JUMPER LINK USE - Values shown are for Premier Panels

Double Pole (jumper links not used)

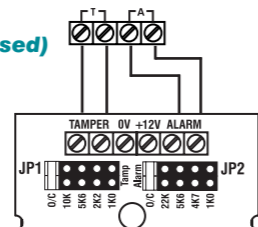

Dual End-of-Line (DEOL)

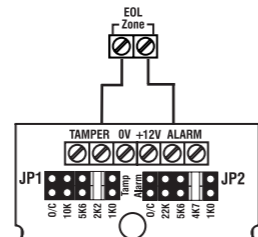

Two DEOL detectors to one zone

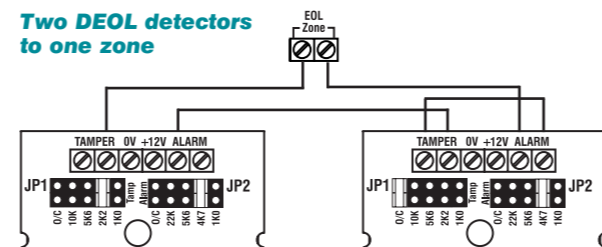

14 DETECTOR KNOCKOUTS

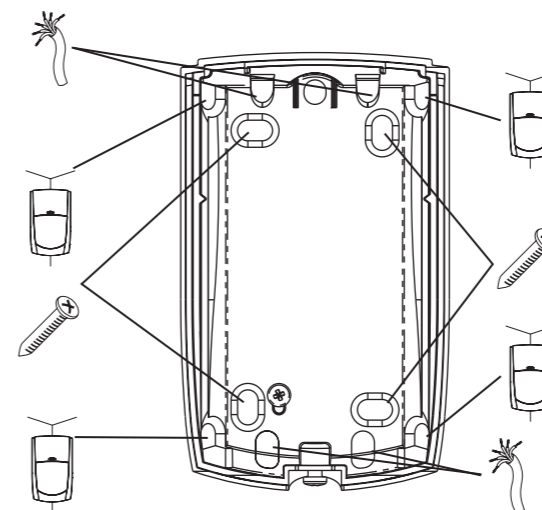

15 CEILING MOUNT BRACKET

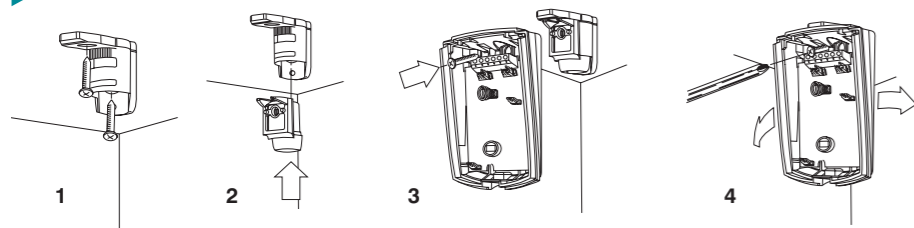

16 WALL MOUNT BRACKET

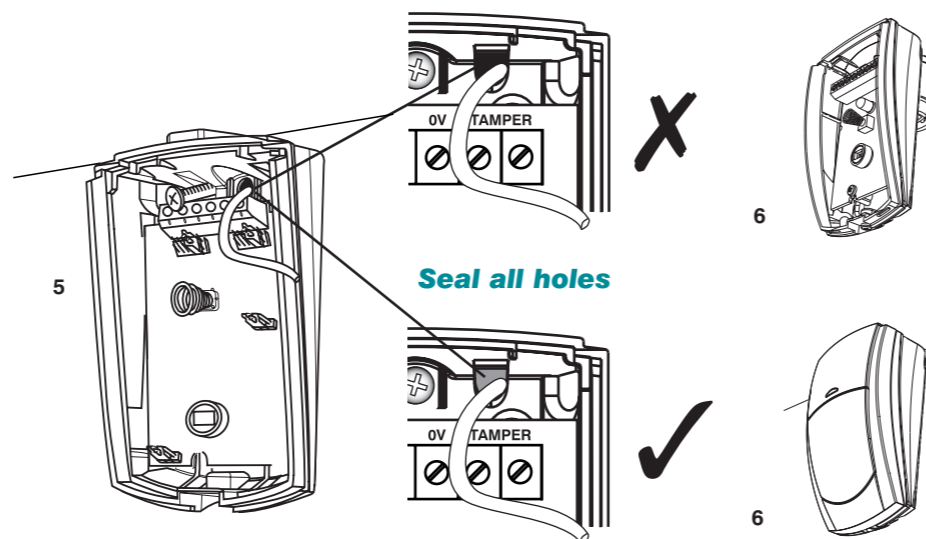
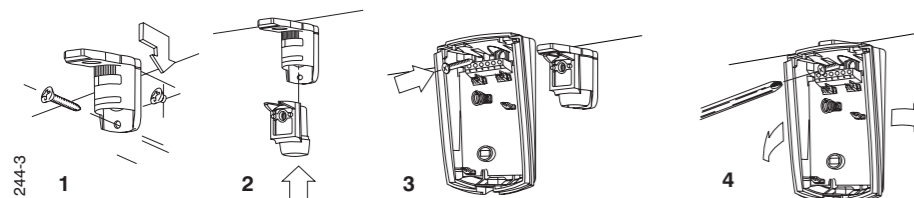

17 MOUNTING WITHOUT BRACKETS

